



# Instrument Handbook

---

MK:440  
Environmental Noise  
Sensor

The content of this manual, any illustrations, technical information and descriptions within this document were correct at the time of going to print. Cirrus Research plc reserves the right to make any changes necessary, without notice, in line with our policy of continuous product development and improvement.

No part of this publication may be duplicated, reprinted, stored in a data processing system or transmitted by electronic, mechanical, photographic or other means, or recorded, translated, edited, abridged or expanded without the prior written consent of Cirrus Research plc.

No liability is accepted for any inaccuracies or omissions in this manual, although due care has been taken to ensure that it is complete and accurate as possible.

Accessories supplied by Cirrus Research plc have been designed for use with the instrumentation manufactured by Cirrus Research plc. No responsibility is accepted for damage caused by the use of any other parts or accessories.

In order to take account of a policy of continuous product development, Cirrus Research plc reserves the right to change any of the information contained in this publication without prior notice.

Produced by Cirrus Research plc, Acoustic House, Bridlington Road, Hunmanby, North Yorkshire, YO14 0PH, United Kingdom.

© Copyright Cirrus Research plc 2022

Reference Number 05/22/MK440/Rev E      IPD-1181-01-AQ

Contents

<b>1</b>	<b>Important information</b> .....	<b>3</b>
<b>2</b>	<b>Product Description</b> .....	<b>4</b>
<b>3</b>	<b>Technical information</b> .....	<b>4</b>
<b>4</b>	<b>Conditions for use</b> .....	<b>4</b>
<b>5</b>	<b>MK:440 Overview</b> .....	<b>5</b>
<b>6</b>	<b>Installation</b> .....	<b>7</b>
6.1	Inspection.....	7
6.2	Location.....	7
6.3	Installation and wiring.....	8
6.4	Earth Bonding.....	9
<b>7</b>	<b>DC Voltage output option</b> .....	<b>9</b>
<b>8</b>	<b>Maintenance &amp; calibration</b> .....	<b>10</b>
8.1	Expose the Microphone .....	10
8.2	Fit Calibrator.....	10
8.3	Measure Output Current.....	10
8.4	Remove Enclosure Cover.....	10
8.5	Adjust Output Current.....	10
8.6	Refit Enclosure Cover .....	11
8.7	Remove Calibrator.....	11
8.8	Refit Windshield and Preamp Assembly .....	11
<b>9</b>	<b>Available Ranges and Equations</b> .....	<b>11</b>
<b>10</b>	<b>Optional Accessories</b> .....	<b>11</b>
<b>11</b>	<b>Cirrus Research Offices</b> .....	<b>12</b>
<b>12</b>	<b>Certificates of Conformity</b> .....	<b>13</b>
12.1	US Certificate of Conformity .....	13
12.2	Canadian Certificate of Conformity.....	15
12.3	Declaration of Conformity.....	17

**1 Important information**

The MK:440 is approved for use in Non Incendive Class 1: Division 2 environments as follows:

Class I, II Division 2, Groups C,D,E,F,G, T4  
 Class I, Zone 2, AEx/Ex ec, IIB, T4  
 Class II, Zone 22 AEx/Ex tc, IIIB, T4  
 (Ta = -30 ≤ Ta ≤ +60°C) IP54

Each MK:440 unit can be configured with unique output levels. Please refer to the factory calibration setup information for the details of your specific instrument.

The MK:440 is supplied with the configuration pre-set to meet those ordered from the factory.

Calpot 'CAL' is referred to in section 8 for calibration. This is the only setting that should be altered by the user during calibration.

Note: The Cirrus MK:440N is functionally identical to the MK:440, but is not approved for use in hazardous locations.

## 2 Product Description

The MK:440 Environmental Noise Monitor is suitable for use in Class 1 Division 2 hazardous locations when installed in accordance with these instructions. The MK:440 conforms to IEC 60079-0 and IEC 60079-15 and is suitable for outdoor installation with a rating of IP54.

For cable entry management the MK:440 is supplied with either a ½" NPT gland (for mating with a suitable conduit), or a ½" compression gland (for direct cable entry).

## 3 Technical information

Parameter	Value			Unit
	Min.	Typical	Max.	
POWER voltage	12	24	27	VDC
LOOPIN voltage	12	24	30	VDC
Current	20		40	mA
Current loop output*	4	-	20	mA
Current loop impedance	-	-	400	Ω
Captive lid screw tightening torque	3		4	Nm
Terminal block tightening torque (J7 & J8)	0.5		0.6	Nm
Weight		2.6		kg
Dimensions(L,W,H)		75,125,480		mm
Operating Temperature	-10		50	°C

**Table 1 Technical Data**

*\*The current output is proportional to the A-weighted noise level, at low noise levels the output can be below 4mA.*

## 4 Conditions for use

**WARNING – DO NOT CONNECT OR DISCONNECT WHEN ENERGIZED**

There are no user replaceable parts within the MK:440. The enclosure lid should only be removed during installation and calibration. The MK:440 should be returned to Cirrus Research for repair, any changes made to the unit will invalidate its approval. The enclosure lid must only be removed if the surrounding area is free from explosive atmosphere.

A portion of the enclosure is non-conducting and, under certain extreme conditions, may generate an ignition-capable level of electrostatic charges. The user shall ensure that the equipment is not installed in a location where it may be subjected to external conditions (such as high-pressure steam) which might cause a build-up of electrostatic charges on non-conducting surfaces. Additionally, cleaning of the equipment should be done only with a damp cloth.

## 5 MK:440 Overview

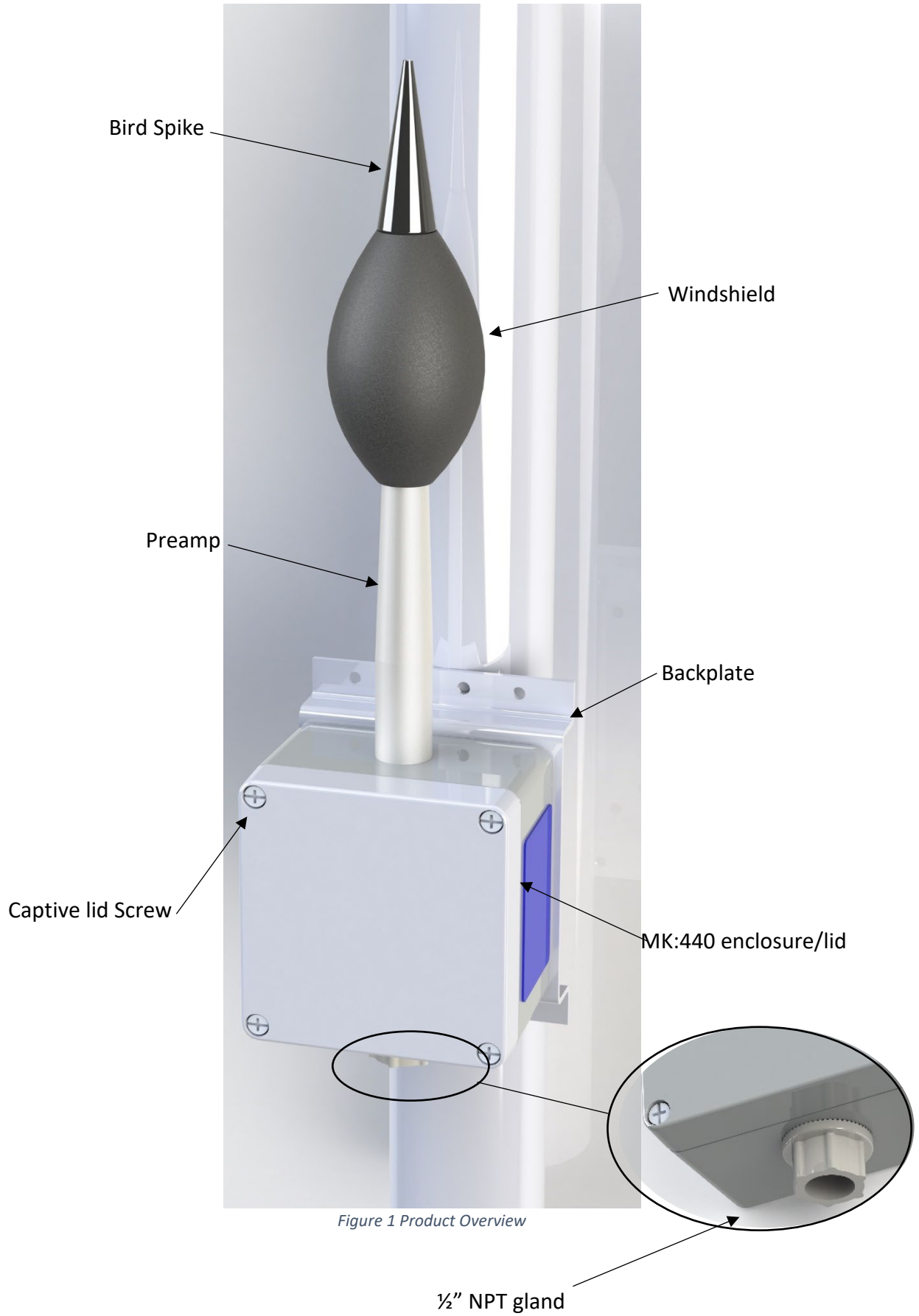

Figure 1 Product Overview

The MK:440 has a 4-20mA current loop that outputs a current level, expressed in milliamperes proportional to the sound level, with either a 'Fast' or 'Slow' time weighting. The choice of time weighting is a factory set option, configurable at the time of purchase.

The output is always weighted with the 'A' frequency weighting which is the most commonly used frequency weighting for the measurement of environmental and industrial noise levels.

The 4-20mA current loop output is ideal for integration to many process measurement and control systems where your own system loggers and software can provide an accurate representation of the 'live' noise levels and also store data.

Your own interface system will need programming with a simple formula which is outlined on your Factory Configuration Information sheet.

For Example:

For a unit with a range of 64 to 134 dB (the default setting if not specified)

Sound Pressure Level  $\text{dB} = (10 \times I) + 20$

(Where "I" is the output current in mA)

Therefore, in this example an output current of 7.4mA would represent a noise level,  $L_A$ , of 94.0dB(A) as shown below:

$$\text{dB(A)} = (10 \times 7.4) + 20$$

$$\text{dB(A)} = 74 + 20$$

$$\text{dB(A)} = 94$$

Please check with our technical department if you need confirmation about the settings of your equipment or if you need any other technical guidance.

## **6 Installation**

Following receipt of your MK:440, complete the next steps to setup and install the equipment.

### **6.1 Inspection**

Inspect the components of the MK:440 and ensure there are no visible defects. In the unlikely event that there is a problem please contact your distributor in the first instance.

### **6.2 Location**

Every site and application are different but here are some basic guidelines for effective positioning of your MK:440:

- To understand the noise profiles for an area, conducting a noise survey or referring to measurement data from a recent noise survey is recommended
- Install the MK:440 in an area where environmental noise is most likely to have an impact
- Legislation often specifies where measurements should be made, for example at property boundaries or at a complainant's property
- Try to mount the unit away from obstacles and building walls
- The instrument should always be a minimum of 1.2m above ground level
- Where possible avoid installing your MK:440 in areas where the microphone will be exposed to high winds as these will affect the noise level readings

### 6.3 Installation and wiring

The MK:440 must be wired in accordance with the National Electric code (NFPA 70) or the Canadian Electric Code (CSA C22.1). An installation drawing below shows the electrical connections to be made to the device.

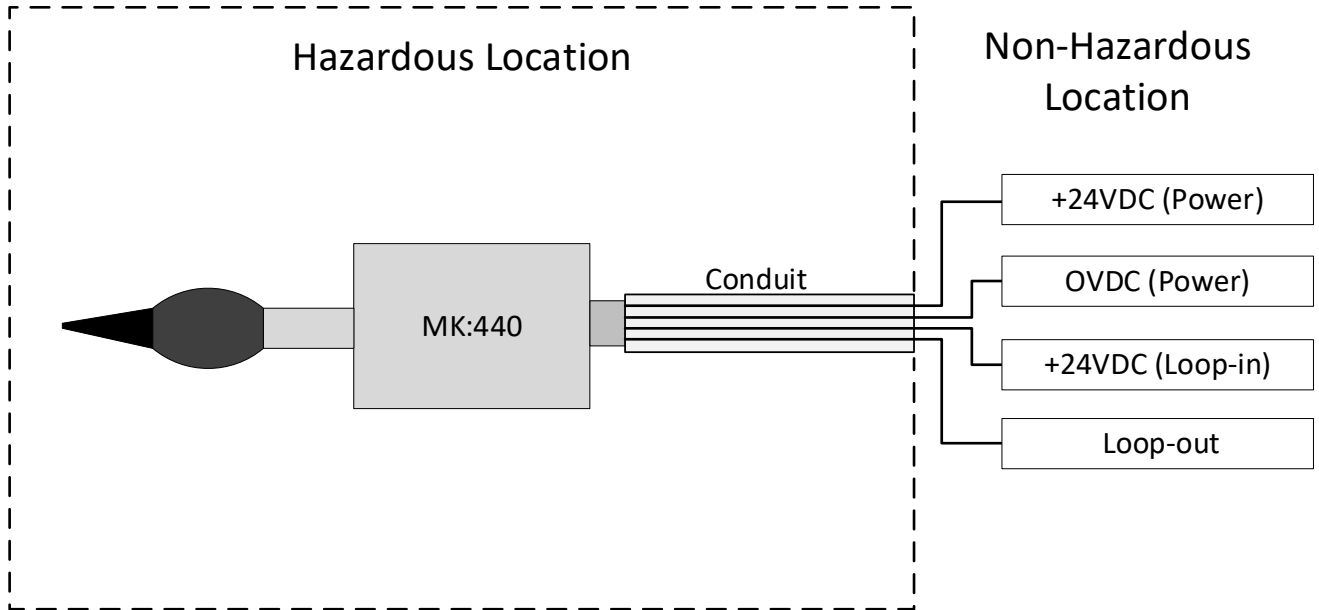

Figure 2 External Wiring

Wherever possible the MK:440 should be wired outside of any potentially explosive atmosphere. A single conductor must be used in each port. The cross-sectional area of the conductor must be between 0.2mm<sup>2</sup> and 0.6mm<sup>2</sup>. The cable must have a temperature rating of at least 80°C and ideally be UL rated. The power and current loop supply must be connected as follows:

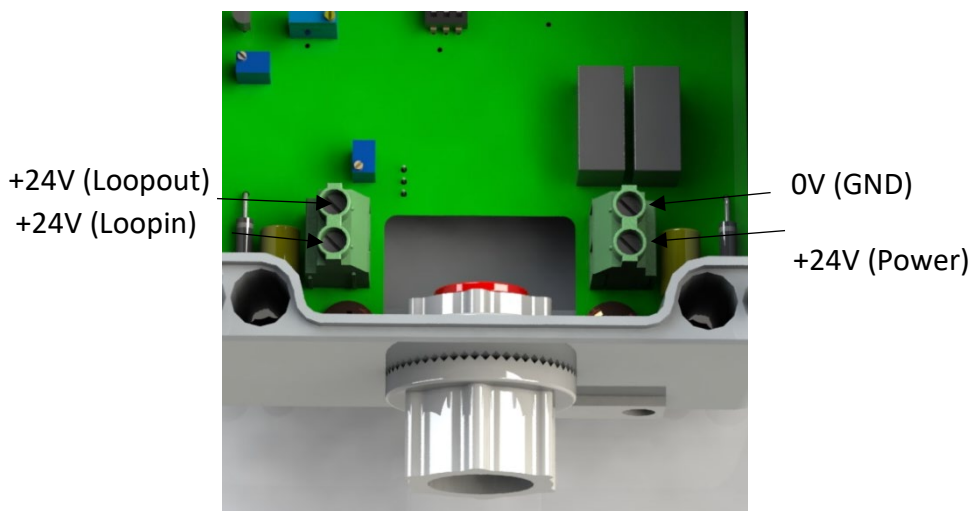

Figure 3 Internal Wiring

There must be no conductor extending beyond the terminal block, strip wires no more than 10mm. When securing conductors in the terminal blocks J7 & J8 do not tighten to more than 0.6 NM, see table 1 in Section 3 of this document



It is the operator’s responsibility to ensure cable routing, conduits and connection to the MK:440 meets with all local safety regulations.

It is advised to perform a calibration before placing the lid on the enclosure (see section 8), adjusting the calibration potentiometer as necessary. If wall mounting kit BP:440 is being used it must be attached to the MK:440 before placing the lid on the enclosure.

A typical wiring diagram is shown below:

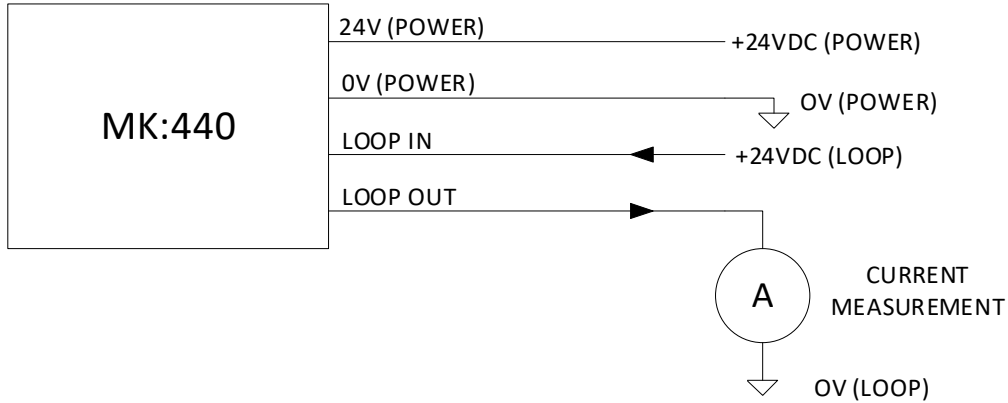

Figure 4 Typical Wiring Diagram

### 6.4 Earth Bonding

The MK:440 has several earth bonding points, it is essential the product is connected to a suitable ground connection. Earthing points are illustrated below:

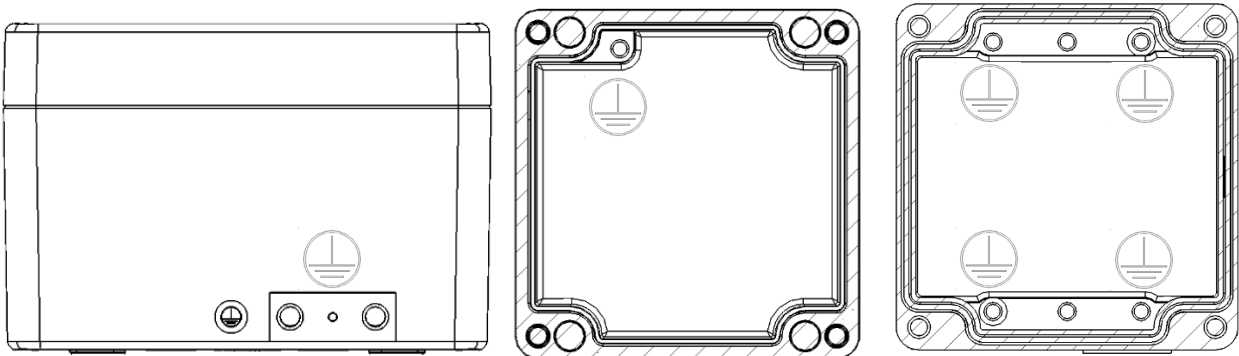

Figure 5 Enclosure Earth Bonding Points

Note that the external and internal earths of the enclosure share an electrical connection, but the lid does not. Both parts of the enclosure must be connected to a suitable ground connection.

### 7 DC Voltage output option

To convert the 4-20mA output current to a 10mV/dB DC voltage output, fit a 100ohm resistor between the LOOP OUT and earth, as shown below.

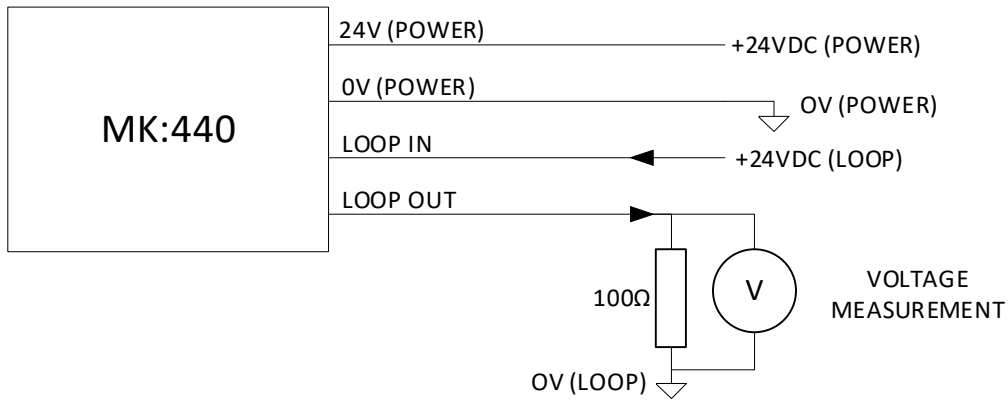

Figure 6 LOOP OUT DC Voltage Wiring

### 8 Maintenance & calibration

The system is designed to be durable and should not need routine maintenance other than calibration. Under no circumstances should the preamp be removed from the enclosure and never remove the microphone from the preamp.

It is recommended that the system is calibrated following initial installation and once a year thereafter to maintain the accuracy of the system.

CAUTION: Calibration must only be carried out by a competent person in a low noise environment when there is no risk of exposure to an explosive atmosphere.

To complete calibration of the MK:440 carry out the following procedure:

#### 8.1 Expose the Microphone

Remove the windshield and top preamp assembly by holding the windshield and black preamp and unscrewing gently to avoid damaging the windshield. This will expose the microphone allowing an acoustic calibrator to be placed over it.

#### 8.2 Fit Calibrator

Use a CR:514/CR:515 94dB calibrator to set an absolute reference point for the system. Turn on the calibrator and place securely on top of the exposed microphone of the MK:440.

#### 8.3 Measure Output Current

Measure the output current of the MK:440, refer to Table 2 in Section 9 of this document to see expected values. If the measured value is equal to the expected value then continue to section 8.7 of this procedure. If the measured value is not equal to the expected value, then carry out steps 8.4 to 8.6 to adjust the output of the MK:440.

#### 8.4 Remove Enclosure Cover

Unscrew the four captive screws that secure the enclosure cover to the enclosure of the MK:440 (see Figure 1 in Section 5 of this document) and remove the cover from the enclosure.

#### 8.5 Adjust Output Current

Turning the screw on the blue multiturn resistor marked 'CAL' will adjust the current output of the MK:440. Adjust the output current so that the measured value equals the expected value shown in Table 2.

NOTE: If turning the 'CAL' screw does not allow you to reach the required output level, complete the remaining steps in this procedure and contact your distributor for support.

### 8.6 Refit Enclosure Cover

Refit the enclosure cover to the enclosure of the MK:440 and secure in place by screwing in the four captive screws, refer to Table 1 in Section 3 of this document for the required torque settings.

### 8.7 Remove Calibrator

Turn off the 94dB calibrator and remove from the microphone of the MK:440.

### 8.8 Refit Windshield and Preamp Assembly

Place the windshield and preamp assembly over the exposed microphone of the MK:440 ensure the threads engage and then gently screw back into place.

## 9 Available Ranges and Equations

The following ranges can be specified for factory delivery (64-134dB is the default setting if not specified):

Nominal Range	DIP SW1/1	DIP SW1/2	DIP SW1/3	I_OUT (mA) DC	Example Value at 9.4mA	Expected I_OUT during calibration**
<b>64-134dBA</b>	<b>ON</b>	<b>OFF</b>	<b>ON</b>	<b><math>dB = (10 \times I) + 20</math></b>	<b>114dB</b>	<b>7.4mA</b>
54-124dBA	ON	ON	OFF	$dB = (10 \times I) + 10$	104dB	8.4mA
44-114dBA*	OFF	OFF	ON	$dB = (10 \times I)$	94dB	9.4mA
34-104dBA*	OFF	OFF	ON	$dB = (10 \times I) - 10$	84dB	10.4mA
24-94dBA	OFF	OFF	OFF	$dB = (10 \times I) - 20$	74dB	11.4mA

Table 2 Configuration Values

\*Note: To change from 114dB to 104dB, adjust the 'CAL' screw

\*\* Using 94dB calibrator

## 10 Optional Accessories

The following accessories may be ordered separately from your distributor as required.

Windshield: UA:440  
 Wall mounting Kit: BP:440  
 Class 2 94dB calibrator: CR:514  
 Class 1 94dB calibrator: CR:515

## 11 Cirrus Research Offices

The addresses given below are the Cirrus Research plc offices. Cirrus Research plc also have approved distributors and agents in many countries worldwide. For details of your local representative, please contact Cirrus Research plc at the address below. Contact details for Cirrus Research authorised distributors and agents are also available from the Cirrus Research web site at the address shown below.

### Main Office:

Cirrus Research plc  
Acoustic House  
Bridlington Road  
Hunmanby  
North Yorkshire  
United Kingdom  
YO14 0PH

Telephone: +44 (0)1723 891655  
E-mail: [sales@cirrusresearch.co.uk](mailto:sales@cirrusresearch.co.uk)  
Web Site: [www.cirrusresearch.co.uk](http://www.cirrusresearch.co.uk)

### Germany:

Cirrus Research plc Deutschland  
Arabella Center  
Lyoner Strasse 44 – 48  
D-60528 Frankfurt  
Germany

Tel: +49 (0)69 95932047

Email: [vertrieb@cirrusresearch.de](mailto:vertrieb@cirrusresearch.de)  
Web: [www.cirrusresearch.de](http://www.cirrusresearch.de)

## 12 Certificates of Conformity

### 12.1 US Certificate of Conformity

<b>CERTIFICATE OF CONFORMITY</b>		 Member of the FM Global Group
1.	<b>HAZARDOUS (CLASSIFIED) LOCATION ELECTRICAL EQUIPMENT PER US REQUIREMENTS</b>	
2.	<b>Certificate No:</b>	<b>FM18US0327X</b>
3.	<b>Equipment: (Type Reference and Name)</b>	<b>MK:440 Sound Monitor</b>
4.	<b>Name of Listing Company:</b>	<b>Cirrus Research PLC</b>
5.	<b>Address of Listing Company:</b>	<b>Acoustic House, Bridlington road Hunmanby, North Yorkshire YO14 0PH</b>
6.	The examination and test results are recorded in confidential report number:  PR450339 dated 8 <sup>th</sup> March 2019	
7.	FM Approvals LLC, certifies that the equipment described has been found to comply with the following Approval standards and other documents:  FM Class 3600:2018, FM Class 3611:2018, ANSI/ISA-12.12.01:2015, FM Class 3810:2018, ANSI/ISA 60079-0:2013, ANSI/UL 60079-7:2013, ANSI/ISA 60079-31:2015, ANSI/IEC 60529:2004	
8.	If the sign 'X' is placed after the certificate number, it indicates that the equipment is subject to specific conditions of use specified in the schedule to this certificate.	
9.	This certificate relates to the design, examination and testing of the products specified herein. The FM Approvals surveillance audit program has further determined that the manufacturing processes and quality control procedures in place are satisfactory to manufacture the product as examined, tested and Approved.	
10.	Equipment Ratings:  Nonincendive for Class I and II, Division 2, Groups C, D, E, F and G; AEx ec for Class I, Zone 2, AEx tc for Class II, Zone 22, Group IIB, T4 for -30°C ≤ Ta ≤ +60°C hazardous (classified) locations; IP54 indoors and outdoors.	
<b>Certificate issued by:</b>		
 J.E. Marquedant VP, Manager, Electrical Systems		8 March 2019 Date
To verify the availability of the Approved product, please refer to <a href="http://www.approvalguide.com">www.approvalguide.com</a>		
<b><u>THIS CERTIFICATE MAY ONLY BE REPRODUCED IN ITS ENTIRETY AND WITHOUT CHANGE</u></b>		
FM Approvals LLC, 1151 Boston-Providence Turnpike, Norwood, MA 02062 USA T: +1 (1) 781 762 4300 F: +1 (1) 781 762 9375 E-mail: <a href="mailto:information@fmapprovals.com">information@fmapprovals.com</a> <a href="http://www.fmapprovals.com">www.fmapprovals.com</a>		
F 347 (Mar 16)		Page 1 of 2

# SCHEDULE



US Certificate Of Conformity No: FM18US0327X

11. The marking of the equipment shall include:

Class I, II, Division 2, Groups C, D; T4, Ta = -30°C to +60°C;  
Class I, Zone 2 / AEx ec / IIB; T4, Ta = -30°C to +60°C;  
Class II, Zone 22 / AEx tc / IIB; T4, Ta = -30°C to +60°C;  
IP54.  
(The label refers to User Manual #IP181AQ1.)

12. **Description of Equipment:**

**General** - The MK:440 Noise Monitor is a robust weatherproof outdoor noise monitor which converts the measured noise level to decibels and provides a standard 4-20 mA output suitable for various process systems including SCADA and DCS. The measurement range has a factory-selectable 70 dB span. The pure analogue noise monitor requires little user intervention and features an easy-to-remove rain protection windshield housing for ease of calibration.

**Construction** – Construction consists of a diecast aluminium enclosure housing the main circuit, machined brass nickel plated preamp housing the preamp circuit and acetal birdspike holding a foam acoustic windshield. Cable entry is zinc 1/2" NPT.

**Ratings** – 27V @40 mA.

**MK:440. Sound Monitor.**

13. **Specific Condition of Use:**

A portion of the enclosure is non-conducting and, under certain extreme conditions, may generate an ignition-capable level of electrostatic charges. The user shall ensure that the equipment is not installed in a location where it may be subjected to external conditions (such as high-pressure steam) which might cause a build-up of electrostatic charges on non-conducting surfaces. Additionally, cleaning of the equipment should be done only with a damp cloth.

14. **Test and Assessment Procedure and Conditions:**

This Certificate has been issued in accordance with FM Approvals US Certification Requirements.

15. **Schedule Drawings**

A copy of the technical documentation has been kept by FM Approvals.

16. **Certificate History**

Details of the supplements to this certificate are described below:

Date	Description
8 <sup>th</sup> March 2019	Original Issue.

**THIS CERTIFICATE MAY ONLY BE REPRODUCED IN ITS ENTIRETY AND WITHOUT CHANGE**

FM Approvals LLC, 1151 Boston-Providence Turnpike, Norwood, MA 02062 USA  
T: +1 (1) 781 762 4300 F: +1 (1) 781 762 9375 E-mail: [information@fmaprovals.com](mailto:information@fmaprovals.com) [www.fmaprovals.com](http://www.fmaprovals.com)

## 12.2 Canadian Certificate of Conformity



Member of the FM Global Group

# CERTIFICATE OF CONFORMITY

1. **HAZARDOUS LOCATION ELECTRICAL EQUIPMENT PER CANADIAN REQUIREMENTS**
2. **Certificate No:** **FM18CA0157X**
3. **Equipment:** **MK:440 Sound Monitor**  
**(Type Reference and Name)**
4. **Name of Listing Company:** **Cirrus Research PLC**
5. **Address of Listing Company:** **Acoustic House, Bridlington road**  
**Hunmanby, North Yorkshire YO14 0P**
6. The examination and test results are recorded in confidential report number:  

PR450339 dated 8<sup>th</sup> March 2019
7. FM Approvals LLC, certifies that the equipment described has been found to comply with the following Approval standards and other documents:  

CAN/CSA-C22.2 No. 213:2015, CAN/CSA-C22.2 No. 60079-0:2015, CAN/CSA-C22.2 No. 60079-7:2016,  
CAN/CSA-C22.2 No. 60079-31:2015, CAN/CSA-C22.2 No. 61010-1:2012, CAN/CSA-C22.2 No.  
60529:R2016.
8. If the sign 'X' is placed after the certificate number, it indicates that the equipment is subject to specific conditions of use specified in the schedule to this certificate.
9. This certificate relates to the design, examination and testing of the products specified herein. The FM Approvals surveillance audit program has further determined that the manufacturing processes and quality control procedures in place are satisfactory to manufacture the product as examined, tested and Approved.
10. **Equipment Ratings:**  

Nonincendive for Class I and II, Division 2, Groups C, D, E, F and G; Ex ec for Class I, Zone 2, Ex tc for Class II, Zone 22, Group IIIB, T4 for -30°C ≤ Ta ≤ +60°C hazardous (classified) locations; IP54 indoors and outdoors.

**Certificate issued by:**

 <hr/> <p>J/E. Marquedant Manager, Electrical Systems</p>	<hr/> <p>8 March 2019 Date</p>
--	------------------------------------

To verify the availability of the Approved product, please refer to [www.approvalguide.com](http://www.approvalguide.com)

**THIS CERTIFICATE MAY ONLY BE REPRODUCED IN ITS ENTIRETY AND WITHOUT CHANGE**

FM Approvals LLC. 1151 Boston-Providence Turnpike, Norwood, MA 02062 USA  
T: +1 (1) 781 762 4300 F: +1 (1) 781 762 9375 E-mail: [information@fmapprovals.com](mailto:information@fmapprovals.com) [www.fmapprovals.com](http://www.fmapprovals.com)

F 348 (Mar 16) Page 1 of 2

# SCHEDULE



Canadian Certificate Of Conformity No: FM18CA0157X

11. The marking of the equipment shall include:

Class I, II, Division 2, Groups C, D; T4, Ta = -30°C to +60°C;  
Class I, Zone 2 / Ex ec / IIB; T4, Ta = -30°C to +60°C;  
Class II, Zone 22 / Ex tc / IIB; T4, Ta = -30°C to +60°C;  
IP54.  
(The label refers to User Manual #IP181AQ1.)

12. Description of Equipment:

**General** - The MK:440 Noise Monitor is a robust weatherproof outdoor noise monitor which converts the measured noise level to decibels and provides a standard 4-20 mA output suitable for various process systems including SCADA and DCS. The measurement range has a factory-selectable 70 dB span. The pure analogue noise monitor requires little user intervention and features an easy-to-remove rain protection windshield housing for ease of calibration.

**Construction** - Construction consists of a diecast aluminium enclosure housing the main circuit, machined brass nickel plated preamp housing the preamp circuit and acetal birdspike holding a foam acoustic windshield. Cable entry is zinc 1/2" NPT.

**Ratings** – 27V @40 mA.

**MK:440. Sound Monitor.**

13. Specific Condition of Use:

A portion of the enclosure is non-conducting and, under certain extreme conditions, may generate an ignition-capable level of electrostatic charges. The user shall ensure that the equipment is not installed in a location where it may be subjected to external conditions (such as high-pressure steam) which might cause a build-up of electrostatic charges on non-conducting surfaces. Additionally, cleaning of the equipment should be done only with a damp cloth.

14. Test and Assessment Procedure and Conditions:

This Certificate has been issued in accordance with FM Approvals Canadian Certification Scheme.

15. Schedule Drawings

A copy of the technical documentation has been kept by FM Approvals.

16. Certificate History

Details of the supplements to this certificate are described below:

Date	Description
8 <sup>th</sup> March 2019	Original Issue.

**THIS CERTIFICATE MAY ONLY BE REPRODUCED IN ITS ENTIRETY AND WITHOUT CHANGE**

FM Approvals LLC. 1151 Boston-Providence Turnpike, Norwood, MA 02062 USA  
T: +1 (1) 781 762 4300 F: +1 (1) 781 762 9375 E-mail: [information@fmaprovals.com](mailto:information@fmaprovals.com) [www.fmaprovals.com](http://www.fmaprovals.com)



### 12.3 Declaration of Conformity



#### Cirrus Research plc Hunmanby UK Declaration of Conformity

Manufacturer: Cirrus Research plc  
Acoustic House, Bridlington Road  
Hunmanby, North Yorkshire, YO14 0PH  
United Kingdom  
Telephone +44 1723 891655

#### Equipment Description

The following equipment manufactured after 30<sup>th</sup> May 2022

MK:440 Environmental Noise Monitor

Along with standard accessories

According to EMC Directives 89/336/EEC and 93/98/EEC meet the following standards

**IEC 61000-6-3:2001** EMC: Generic emission standard for residential, commercial and light industrial environments.

**IEC 61000-6-1:2001** EMC: Generic immunity standard for residential, commercial and light industrial environments.

**ANSI/ISA 60079-0:2013** Explosive atmospheres – Part 0: Equipment – General requirements

**ANSI/ISA 60079-7:2013** Explosive atmospheres – Part 7: Equipment protection by increased safety “e”

**ANSI/ISA 60079-31:2015** Explosive atmospheres – Part 31: Equipment dust ignition protection by enclosure “t”

**FM 3600** Electrical Equipment for Use in Hazardous (Classified) Locations – General Requirements

**FM 3611** Nonincendive Electrical Equipment for Use in Class I and II, Division 2, and Class III, Divisions 1 and 2, Hazardous (Classified) Locations

Signed

Dated 30 May 2022

A handwritten signature in black ink, appearing to read 'M. Williams', with a stylized flourish extending to the right.

M. Williams  
Chief Engineer



[www.cirrusresearch.com](http://www.cirrusresearch.com)  
[sales@cirrusresearch.com](mailto:sales@cirrusresearch.com)